

Oxiperm[®] Pro

Safe, reliable, on-site generation and dosing of chlorine dioxide for water disinfection



1. Product introduction	3
Introduction	3
Applications	3
Features and benefits	4
2. Components	6
3. Identification	8
Type key	8
4. Construction	9
Oxiperm Pro OCD-162-5 and OCD-162-10	9
Oxiperm Pro OCD-162-30 and OCD-162-60	10
5. Installation	11
Preparation	11
6. Technical data	13
Electrical and electronic data	14
Dimensions	15
7. Product selection	18
How to size Oxiperm Pro®	18
8. Accessories	19
Dosing pumps	19
ClO ₂ pump control cables	19
Multifunction valve	19
Injection valve	19
Connectors	19
Instrumentation	20
Conex DIA-G gas warning unit	20
Photometer	20
Suction lines	20
Connections	21
Annual maintenance kits	21
9. Further product documentation	22
WebCAPS	22
WinCAPS	23

1. Product introduction

Introduction

Oxiperm Pro systems produce chlorine dioxide using dilute solutions of sodium chlorite (NaClO_2 7.5 %) and hydrochloric acid (HCl 9 %). The systems are available in four size ranges, producing a maximum of 5, 10, 30 and 55 g/h of chlorine dioxide, respectively. The largest unit is capable of generating chlorine dioxide in an amount sufficient to treat up to 660 gpm (150 m³/h) of potable water at the maximum admissible concentration of 0.8 mg/l ClO_2 . Chlorine dioxide is produced on demand from diluted solutions using sodium chlorite/hydrochloric acid.

The chlorine dioxide solution produced is stored in either an integrated or external batch tank, while the required addition of the disinfectant to the water line is accomplished via either an integrated or external dosing pump.

Chlorine dioxide is highly effective against a wide variety of pathogens. Additionally, it demonstrates a prolonged residence time in piping systems, eliminating the requirement for re-dosing downstream.

A significant advantage of chlorine dioxide over other disinfectants is its effectiveness against biofilms. Biofilm is a slimy layer on the inside of water pipes or on process equipment, where pathogens build up and reproduce. Chlorine dioxide destroys the existing biofilm, thus removing a primary area for the growth of pathogens, while preventing recurrent biofilm buildup.

Applications

Oxiperm Pro OCD-162-5 and -10 systems are designed for small or medium-sized systems with water flows up to 110 gpm (25 m³/h). Oxiperm Pro OCD-162-30 and -60 systems are suited for medium or large-sized systems; and disinfection tasks in waterworks or applications in the food and beverage industry. All four units are ideal for use in cooling tower or chilled loop disinfection for systems of various sizes.

Ideal applications for Oxiperm Pro include combating pathogens such as legionella pneumophila (cause of Legionnaires disease) in building, cooling tower, industrial and municipal water systems.

No chance for pathogens

Legionella are rod-shaped bacteria that enter drinking water systems and start to reproduce. Legionella reproduce especially quickly in temperatures between 85 °F (29 °C) and 105 °F (41 °C).

The bacteria can enter the lungs when a person inhales aerosols containing legionella while showering or in cooling tower drift. They can cause a life-threatening form of pneumonia known as legionellosis (Legionnaires disease).

Biofilms are an ideal breeding ground for legionella in drinking water systems. Legionella also establish themselves in amoebae, which offer them protection against conventional disinfection methods.

Typically, disinfection is the first step of pathogen reduction within continuing operations of a drinking water installation. An ideal means of ensuring safe drinking water is to use chlorine dioxide as a disinfectant.

In addition to its use as a primary disinfectant for potable and process water, chlorine dioxide is often used in the food and beverage industries for CIP (clean in place) and bottle washing. This is due to the fact that the use of chlorine dioxide does not alter the smell or taste of the treated water. This results in the elimination of concerns having to do with alteration of the food product's characteristics.

Effectiveness diagram

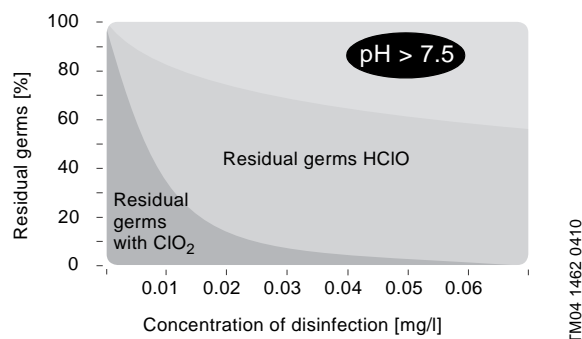

Fig. 1 Effectiveness diagram: HClO = hypochlorous acid, ClO_2 = chlorine dioxide

Features and benefits

Compact system

Oxiperm Pro can also be installed in tight or restrictive spaces, as operation and maintenance are performed exclusively from the front.

Low operating costs

This intelligent method for producing chlorine dioxide functions with minimal need for chemicals and thus saves up to 67 % of hydrochloric acid over other systems on the market with comparable capacity. In comparison with thermal disinfection, up to 90 % of the operating costs can be saved.

Stable product solution

With a chlorine dioxide concentration of 2 g/l (2000 ppm), the product solution can be stored for several days. The low concentration makes the solution safe to handle.

Integrated measurement value logging device (optional)

The chlorine dioxide control unit can be easily retrofitted, as the connection for a measuring device for chlorine dioxide as well as pH or Redox (measuring cell) is already in place in the system control.

Little installation work

Optional accessories simplify assembly and start-up. In fact, the system can be connected and taken into operation without even interrupting the building's water supply. This represents a decisive cost factor when it comes to decontaminating hospitals or nursing homes.

Robust design

Oxiperm Pro's robust design ensures high operational reliability and lower maintenance costs. Furthermore, the newly designed control system makes for straightforward and user-friendly operation and opens up a number of application areas for discrete disinfection of drinking water installations.

Wide field of applications

Besides continuous operation, the optional external batch tank allows the use of Oxiperm Pro for shock disinfection, in cleaning applications, such as CIP, or for multi-point injection.



Fig. 2 Oxiperm Pro systems

TM04 1461 0310

This page intentionally left blank.

2. Components

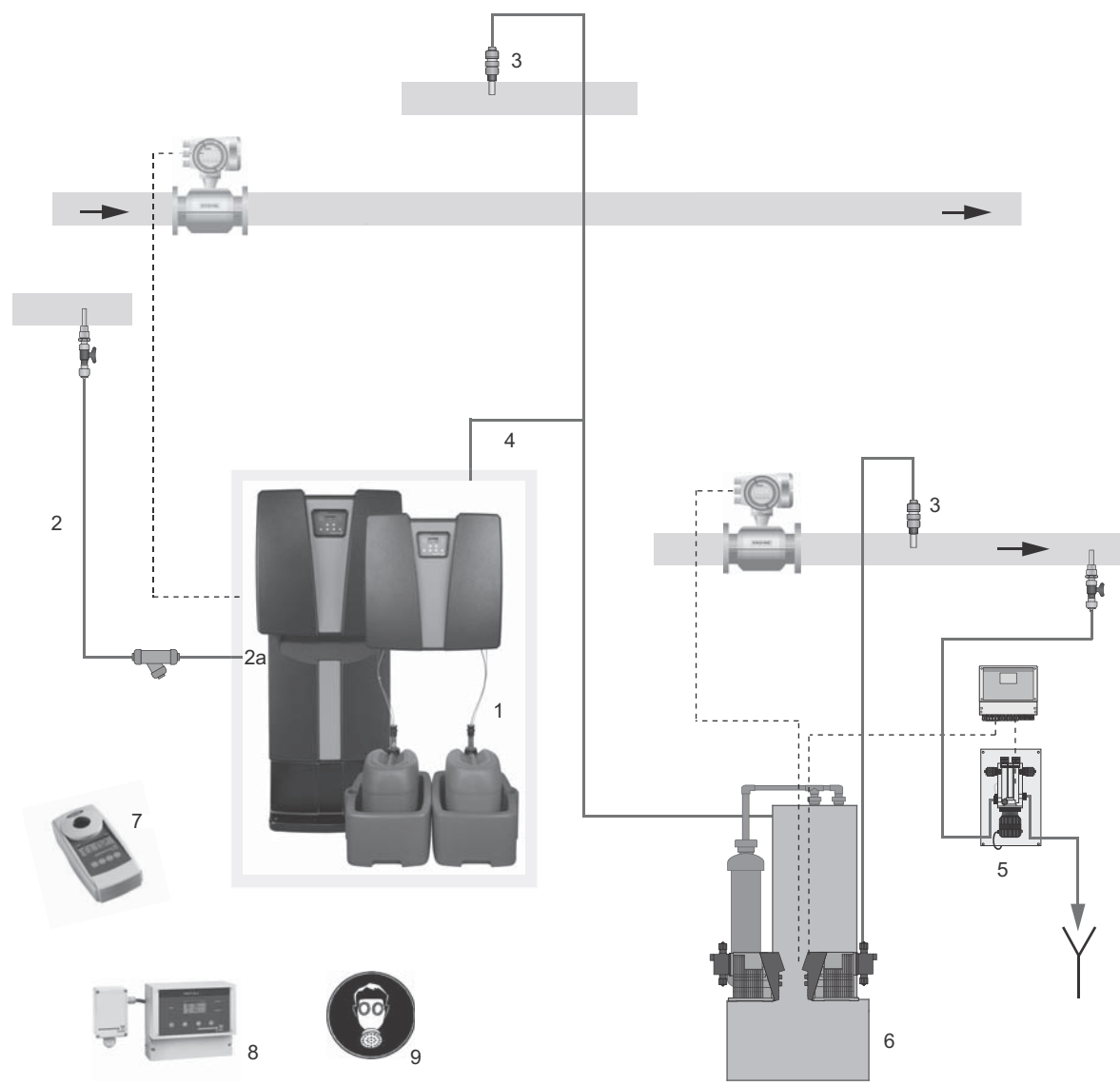

Fig. 3 Components of an installation for chlorine dioxide preparation

TM05 3873 1712

Checklist of installation components

No.	Component	Page
Basic unit		
1	Oxiperm Pro chlorine dioxide preparation system	9
Dilution water for Oxiperm Pro		
2	PE hose 1/4" x 3/8" for dilution water connection	13
2a	Alternative 1/2" NPT connection	19
Dosing of chlorine dioxide		
3	Injection valve for the direct dosing of chlorine dioxide into the water pipe Inlet: 1/4", 3/8", 1/2" tube; 1/2" NPT Discharge: 1/2" NPT	19
4	ClO ₂ line 162 5 and 10: 1/8" ID x 1/4" OD tubing connection 162 30 and 60: 1/4" ID x 3/8" OD tubing connection 1/2" NPT connections available for all sizes	13 19
Chlorine dioxide measurement		
5	ClO ₂ measuring cell, 3/8" x 1/2" tubing inlet/discharge	20
6	External batch tanks	
7	Hand photometer with reagents for calibrating ClO ₂ controller	20
Safety equipment		
8	Gas warning unit	20
9	Personal protective equipment (gloves, apron, goggles), warning signs	
Maintenance		
	Annual maintenance kit	

3. Identification

Type key

Example: Type key Oxiperm Pro OCD-162-30-P/H3

Oxiperm Pro	OCD-162	-30	-P	/H	3
Max. Capacity					
5	5 g/h				
10	10 g/h				
30	30 g/h				
60	55 g/h				
Operation mode					
D	integrated mechanical dosing pump, DMX				
P	integrated Digital Dosing pump DDI				
S	integrated SMART Digital Dosing pump DDA				
N	without integrated ClO ₂ dosing pump				
Supply voltage					
G	230-240 V / 50-60 Hz				
H	110-120 V / 50-60 Hz				
Suction line					
	for 7.9 gal (30 liter) chemical tank, with 4.3 ft (1.3 m) of tubing				
1	for 15.6 gal (60 liter) chemical tank, with 9.8 ft (3.0 m) of tubing				
2	for 52.8 gal / 264.2 gal (200 liter / 1000 liter) chemical tank, with 19.7 ft (6.0 m) of tubing				
3	for 55 gal drum, with 9.8 ft (3.0 m) of tubing				

4. Construction

Oxiperm Pro OCD-162-5 and OCD-162-10

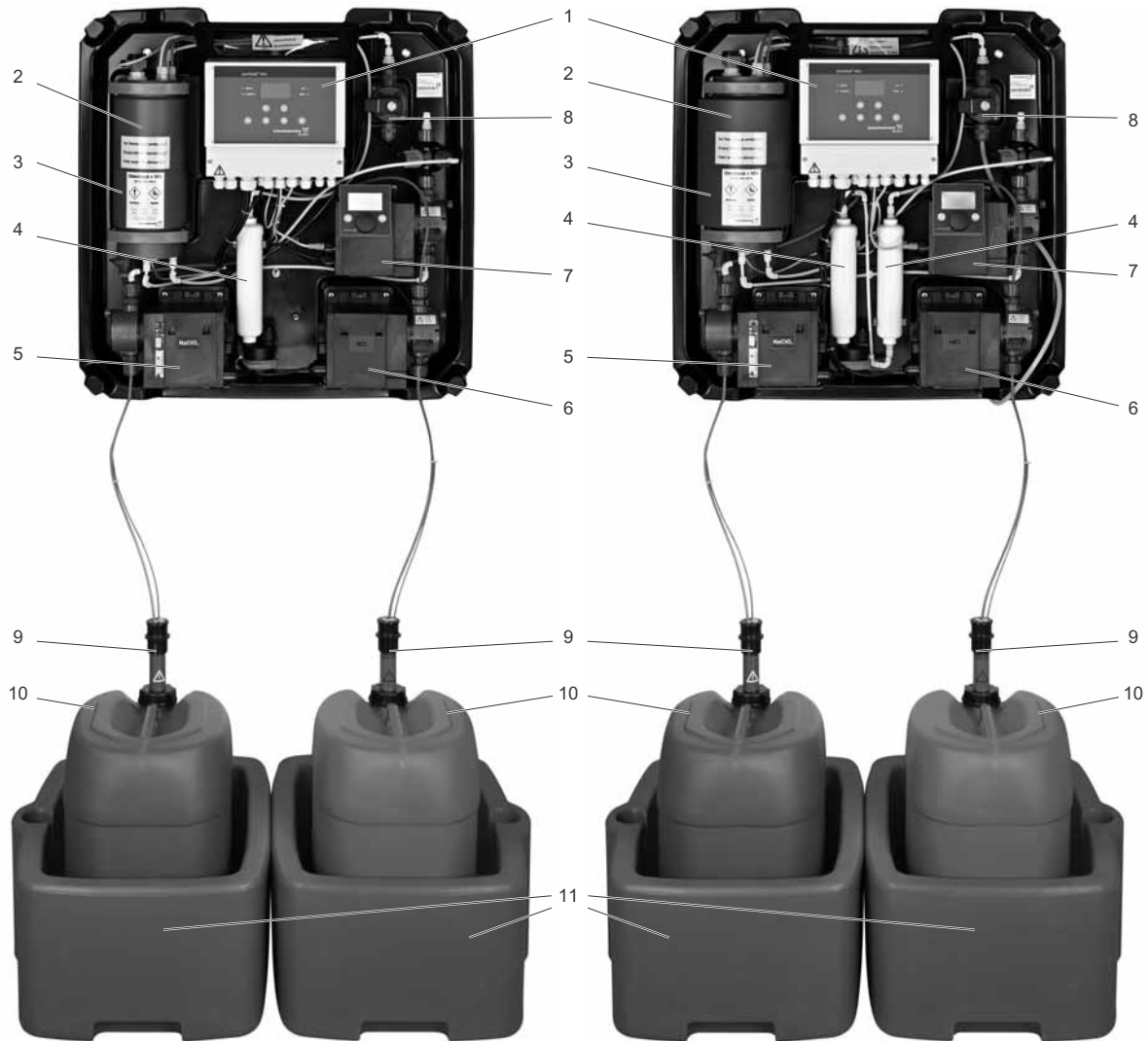

Fig. 4 Oxiperm Pro OCD-162-5 (left) and Oxiperm Pro OCD-162-10 (right) with open housing

Legend

1	Measuring and control unit
2	Reaction tank
3	Reservoir tank
4	Adsorption filter
5	Dosing pump, 7.5% Sodium Chlorite
6	Dosing pump, 9% Hydrochloric Acid
7	Chlorine Dioxide dosing pump
8	Solenoid valve for dilution water
9	Suction lance
10	Chemical container (not in standard delivery)
11	Collecting tray (not in standard delivery)

TM04-8507-0912

Oxiperm Pro OCD-162-30 and OCD-162-60

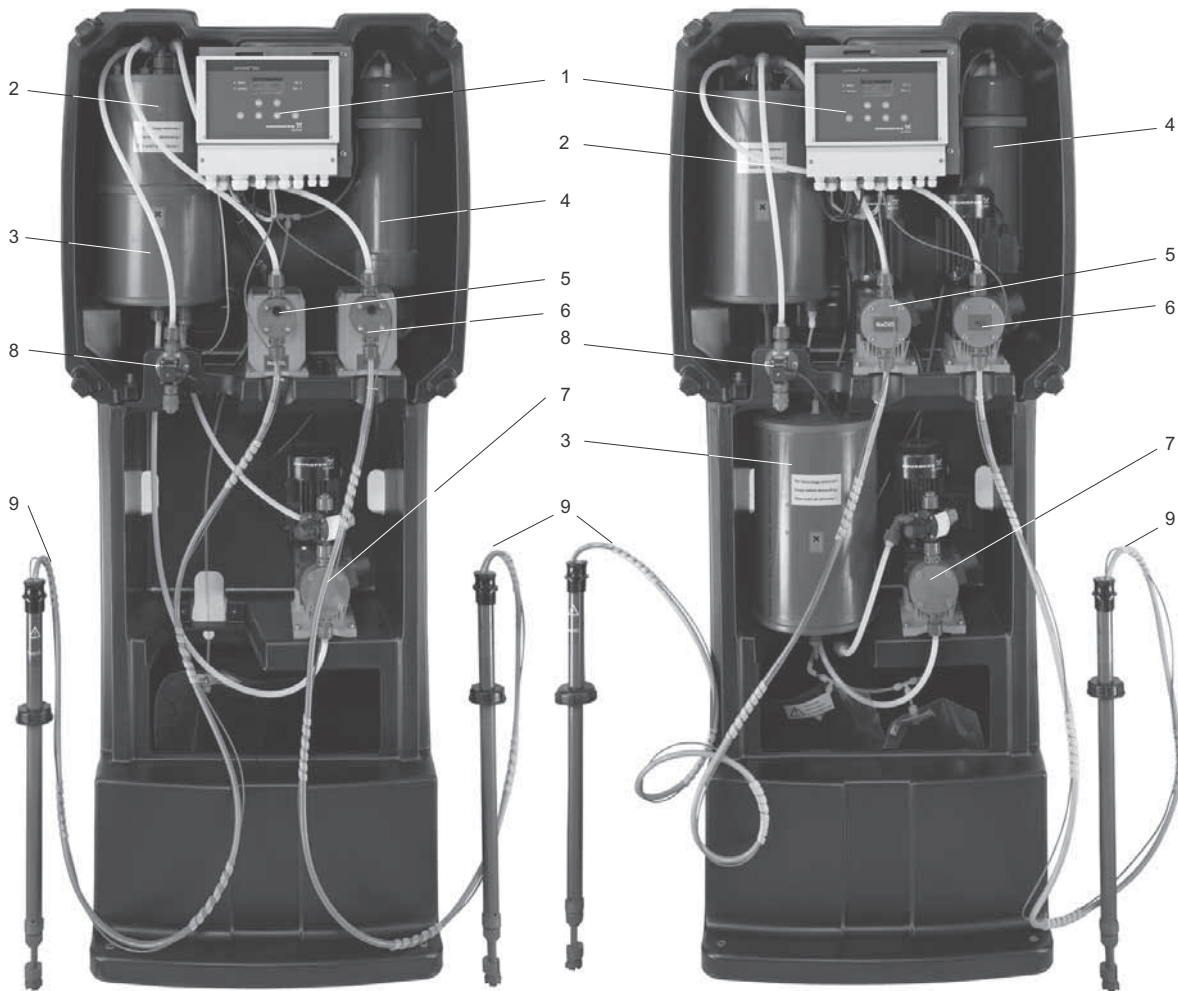

Fig. 5 Oxiperm Pro OCD-162-30 (left) and Oxiperm Pro OCD-162-60 (right) with open housing

Legend

1	Measuring and control unit
2	Reaction tank
3	Reservoir tank
4	Adsorption filter
5	Dosing pump, 7.5% Sodium Chlorite
6	Dosing pump, 9% Hydrochloric Acid
7	Chlorine Dioxide dosing pump
8	Solenoid valve for dilution water
9	Suction lance

TM04 1483 0410

5. Installation

Preparation

One dosing point

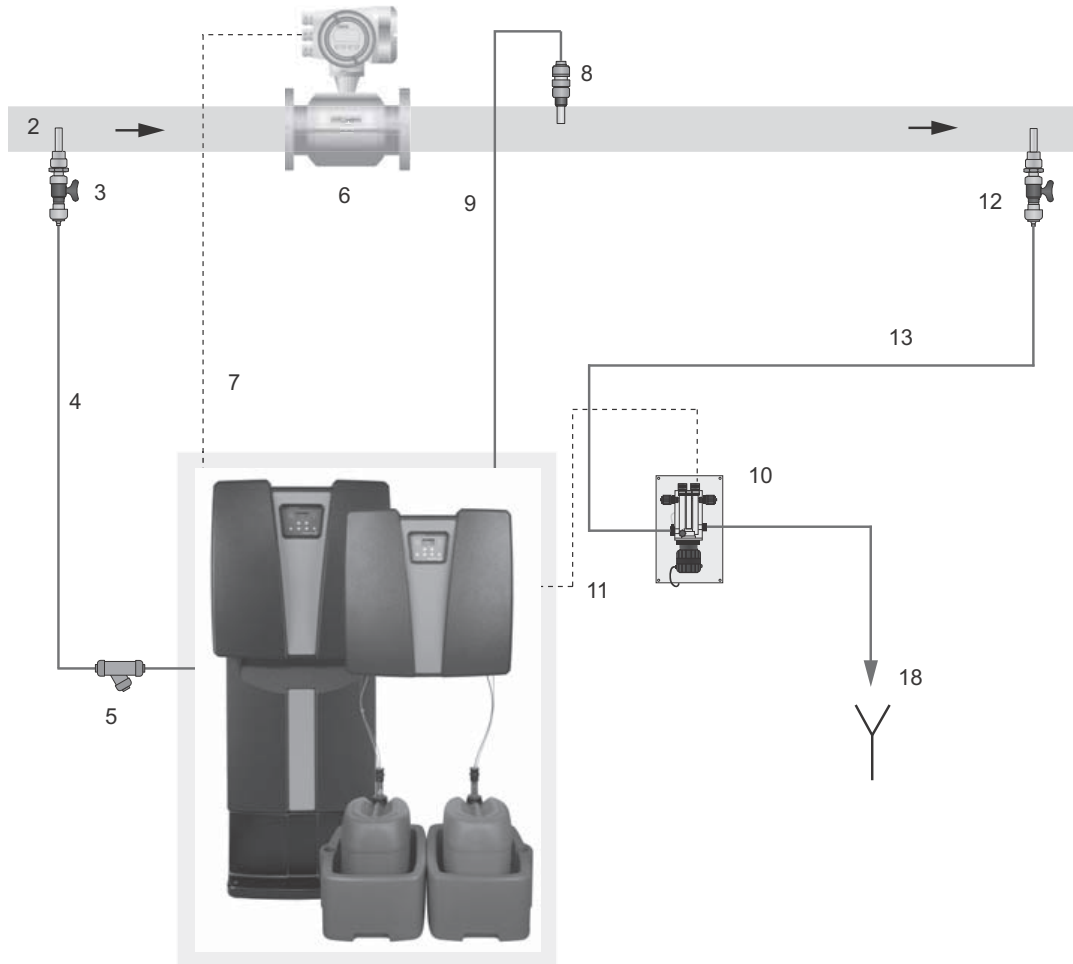

Fig. 6 Oxiperm Pro basic module with optional measuring cell for chlorine dioxide in cold water

Legend

1	Oxiperm Pro OCD-162-5, -10, -30, or 60
2	Main water pipe
3	Dilution water extraction point
4	Dilution water pipe
5	Y-Strainer
6	Flow measurement
7	Signal line flow measurement
8	Injection unit
9	Dosing line
10	Chlorine dioxide measuring cell
11	Signal line chlorine dioxide measurement
12	Sample water extraction point (minimum distance of approx. 17 ft (5 m) from ClO ₂ injection point)
13	Sample water line to measuring cell
18	Sample water drain line

TM05 6867 0213

Several dosing points with batch tank

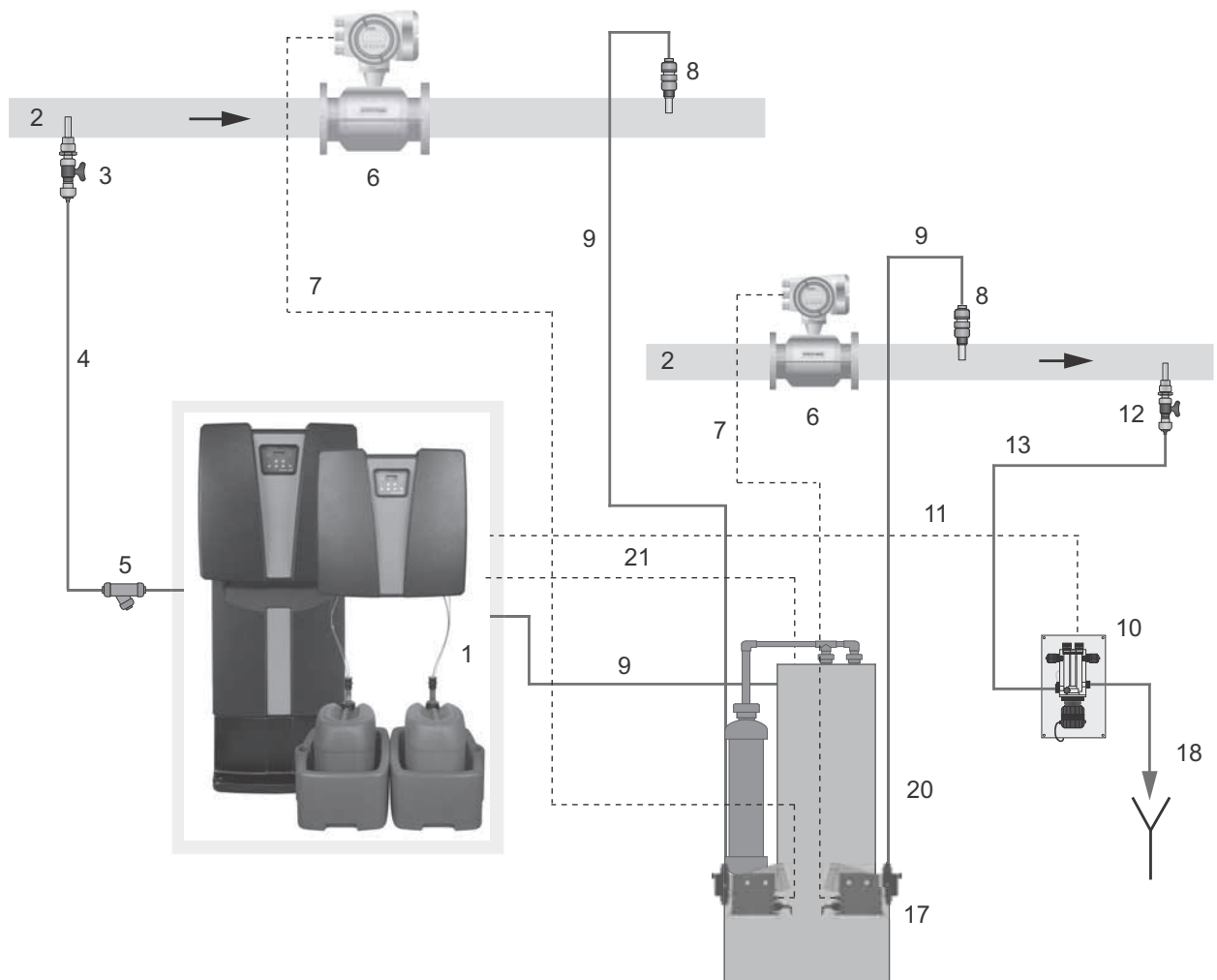

TM05 6868 0213

Fig. 7 Oxiperm Pro basic module with additional dosing pumps on a batch tank and optional chlorine dioxide measurement

Legend

1	Oxiperm Pro
2	Main water pipe
3	Dilution water extraction point
4	Dilution water pipe
5	Y-Strainer
6	Flow measurement
7	Signal line flow measurement
8	Injection unit
9	Dosing line
10	Chlorine dioxide measuring cell
11	Signal line chlorine dioxide measurement
12	Measuring water extraction point (min. distance to injection unit approx. 17 ft (5 m))
13	Sample water pipe
17	Additional ClO ₂ dosing pumps
18	Sample water drain
20	Batch tank
21	Signal line batch tank

6. Technical data

Chlorine dioxide generator		OCD model				
		162-5	162-10	162-30	162-60	
ClO ₂ production	[lbs/day (grams/hr)]	0.26 (5)	0.53 (10)	1.59 (30)	2.9 (55)	
ClO ₂ concentration	[ppm]	2000				
Max continuous ClO ₂ dosing feed rate* (i.e. max. ClO ₂ pump output at 20mA)	[gal/hr (l/hr)]	0.66 (2.5)	1.32 (5)	3.96 (15)	7.26 (27.5)	
Consumption data	[gal/hr (l/hr)]	NaClO ₂	0.044 (0.17)	0.097 (0.37)	0.232 (0.88)	0.41 (1.57)
		HCl	0.036 (0.14)	0.079 (0.3)	0.227 (0.86)	0.39 (1.49)
		H ₂ O	0.607 (2.3)	1.268 (4.8)	3.909 (14.8)	7.87 (29.79)
Precursor concentration by weight	HCl	9 %				
	NaClO ₂	7.5 %				
Precursor safety equipment		Capacity monitored via level control				
Temperature range	[°F (°C)]	Ambient	40 to 95 °F (5 to 35 °C)			
		Dilution H ₂ O	50 to 85 °F (10 to 30 °C)			
		HCl & NaClO ₂	50 to 95 °F (10 to 35 °C)			
Dilution water pressure	[psi (bar)]	44 to 87 psi (3 to 6 bar)				
Admissible relative air humidity		max. 80 %, not condensing				
Total volume - reaction tank	[gal (liters)]	0.26 (1.0)	0.48 (1.8)	1.6 (6.1)	3.5 (13.4)	
Total volume - reservoir tank (up to max level alarm)	[gal (liters)]	0.26 (1.0)	0.48 (1.8)	1.85 (7.0)	3.67 (13.9)	
Filling volume - reaction tank	[gal (liters)]	0.23 (0.87)	0.44 (1.67)	1.46 (5.52)	3.16 (11.96)	
Filling volume - reservoir tank (up to max level alarm)	[gal (liters)]	0.23 (0.87)	0.44 (1.67)	1.72 (6.5)	3.43 (13.0)	
Materials of construction	System rack	Polypropylene				
	Fastening sleeves	Stainless steel				
	Solenoid valve	PVC				
	Reaction/reservoir tank	PVC				
	Internal hoses	PTFE				
	Gaskets	FPM				
Connections	ClO ₂ dosing line	1/8" ID x 1/4" OD tube		1/4" ID x 3/8" OD tube		
	Dilution water	1/4" ID x 3/8" OD tube				
	NPT adaptor	1/2" NPT connector - see 8. Accessories on page 19.				
Full text menu control	Commissioning	Yes				
	Operation parameters	Yes				
	Flush / rinsing	Yes				
	Maintenance	Yes				
Approvals	Electrical safety	 Conforms to ANSI/UL 61010-1				
	NSF 61 PWT	Chlorine Dioxide Generator model numbers OCD-162-5, OCD-162-10, OCD-162-30 and OCD-162-60 are certified to NSF 61-2011 requirements found in clause 3.3.2. (a) These chemical generators are certified for use exclusively at public water treatment facilities. Products installed at public water treatment facilities are considered to be used in high flow applications. (b) Certification of this product has been performed to the health effects requirements of NSF/ANSI 61, which assesses the acceptability of potential extractants from the chemical generator. No evaluation has been performed on the strength or efficacy of the chemical generated under this certification. The generated chemical has not been certified by UL to NSF/ANSI 60. The operation, maintenance, and the consistency of the source ingredients may affect the performance of the chemical generator and by-products in the chemical being generated. Consult the manufacturer's product literature for proper usage.				

*Derated suggested maximum pump output for continuous ClO₂ feed.

Electrical and electronic data

Chlorine dioxide generator	OCD model			
	162-5	162-10	162-30	162-60
Mains connection	110/120 V / 50-60 Hz (230/240 V / 50-60Hz also available)			
Enclosure rating	IP65			
Power consumption	50 VA		180 VA	320 VA
Analog inputs	input 0(4)-20 mA (water/flow meter), Load: 50 Ω			
	ClO ₂ controller, pH/ORP and temperature sensor			
	contact/pulse flow meter (min. 3 pulses/min., max. 50 pulses/sec.)			
Digital inputs	remote Start/Stop			
	Gas warning alarm			
Analog outputs	(0)4-20mA control of ClO ₂ pump			
	ClO ₂ measured value (0)4-20mA			
	250 V/6 A, max. max. 550 VA			
	ClO ₂ Alarm (upward / downward violations)			
	Chemicals-empty signal			
	Dosing time monitoring			
Potential-free outputs	Preparation process time monitoring			
	Wire-break current output			
	250 V/6 A, max. max. 550 VA			
	Chemicals-low level signal			
	Maintenance / Service			
	Alarm relay			
	Warning relay			

Dimensions

Oxiperm Pro OCD-162-5 and OCD-162-10

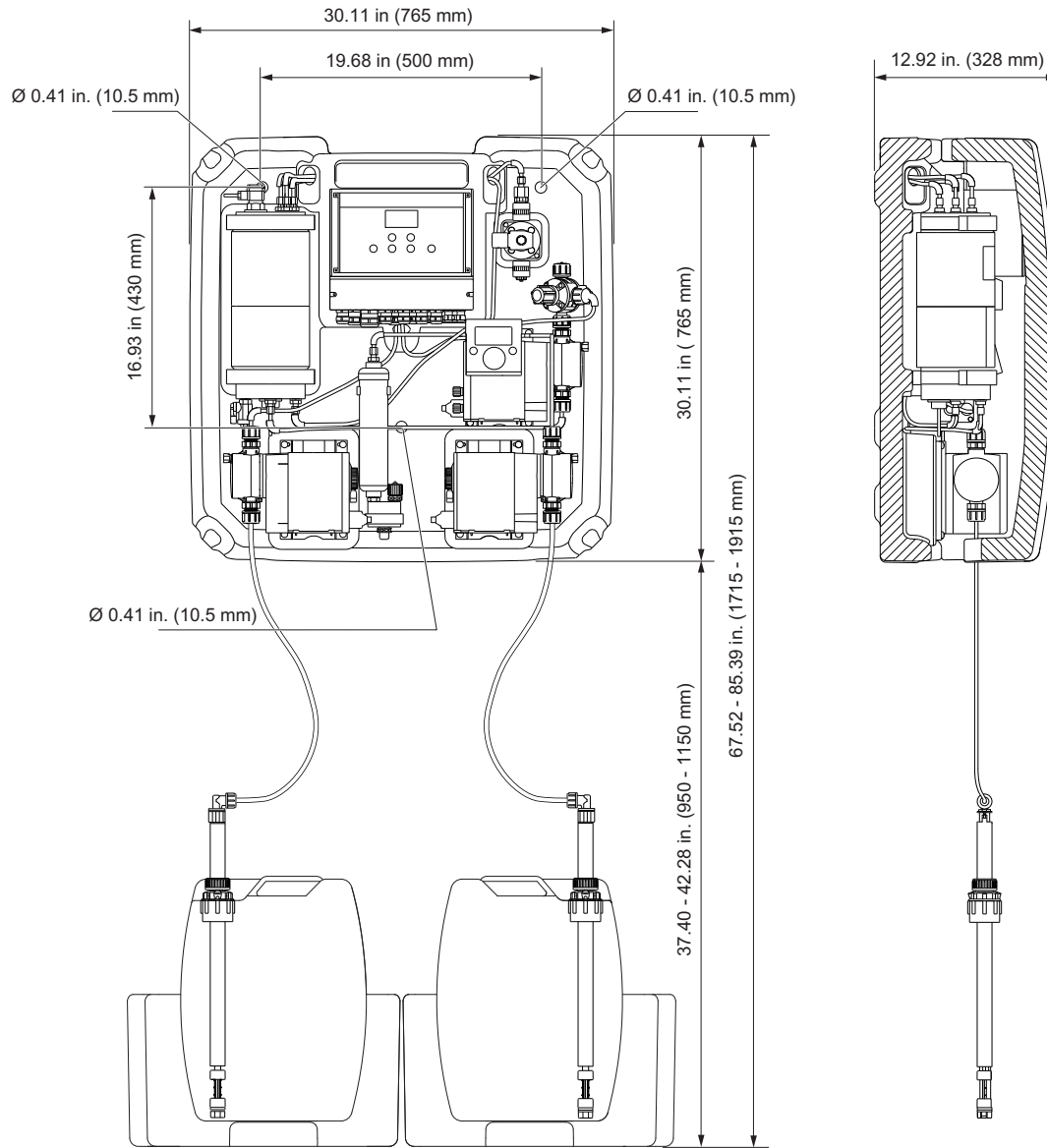

Fig. 8 Dimensional sketch, Oxiperm Pro OCD-162-5 and OCD-162-10

TM05 4065 1812

Oxiperm Pro OCD-162-30 and OCD-162-60

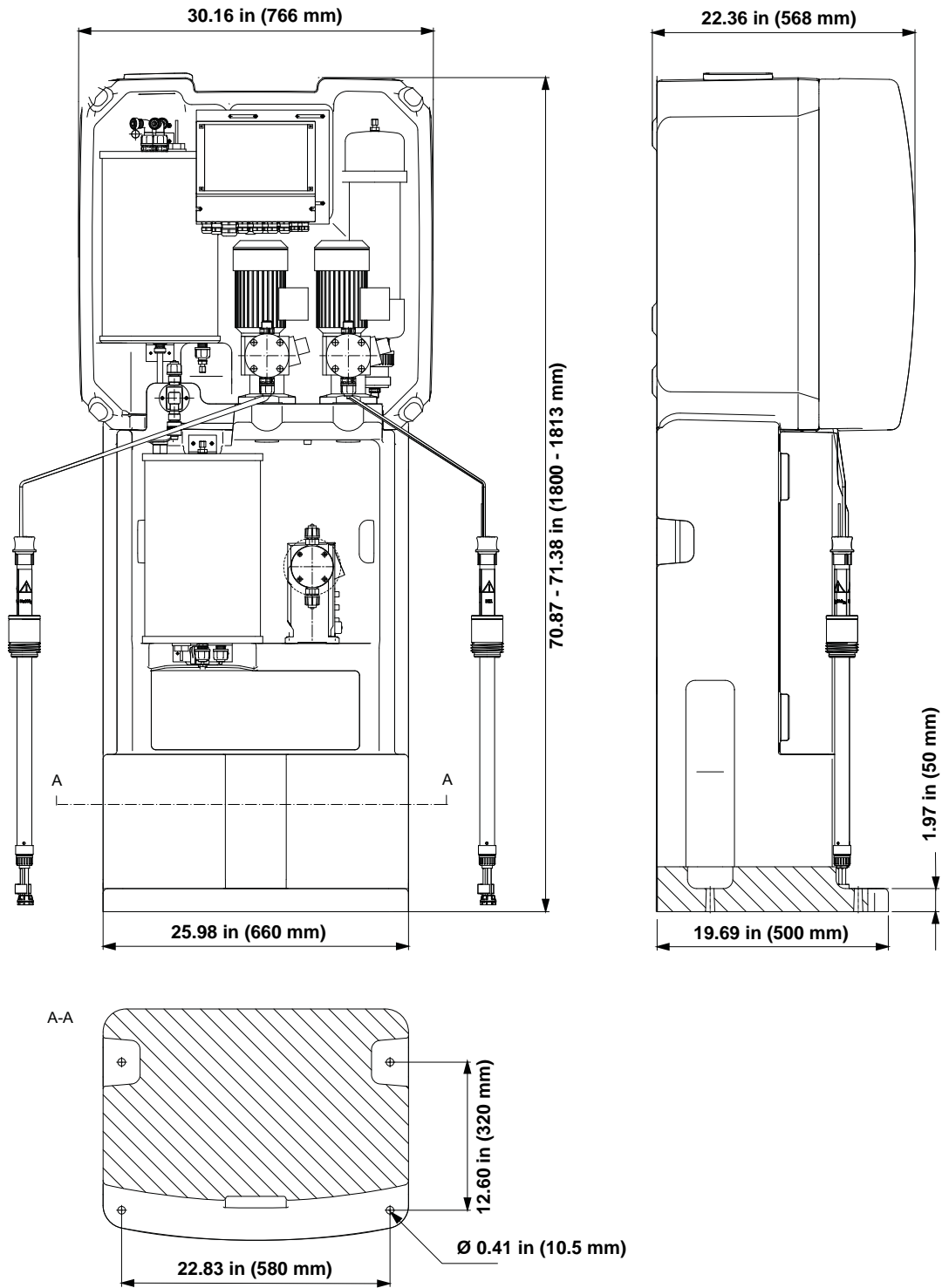

Fig. 9 Dimensional sketch, Oxiperm Pro OCD-162-30/-60

TM05 3874 1712

Suction lance adaptors for chemical containers

The adaptor suitable for the respective container is included with the suction lance.

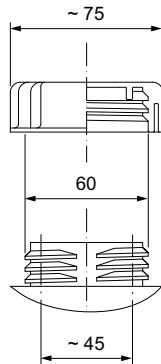

Fig. 10 Suction lance adaptor for 30-liter container (Oxiperm Pro OCD-162-5, -10, -30)

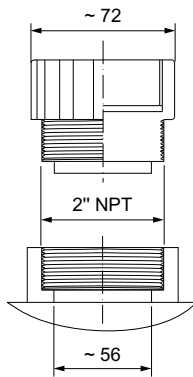

Fig. 11 Suction lance adaptor for 55-gallon container (Oxiperm Pro OCD-162-5, -10, -30, -60)

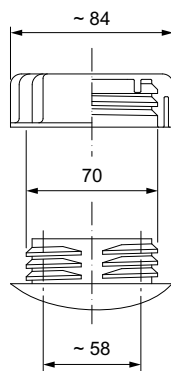

Fig. 12 Suction lance adaptor for 60-liter container (Oxiperm Pro OCD-162-30, -60)

TM04 8536 1312

TM04 8537 1312

TM04 8538 1312

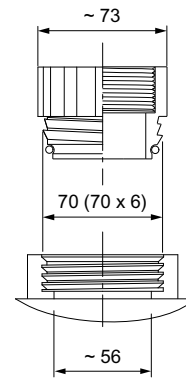
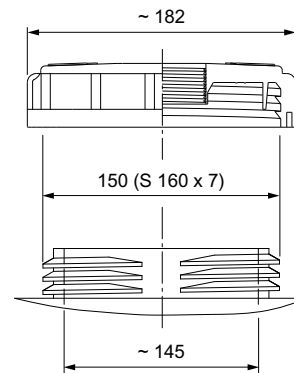

Fig. 13 Suction lance adaptor for 200-liter container (IBC) (Oxiperm Pro OCD-162-30, -60)

TM04 8539 1312



Suction lance adaptor for 1000-liter container (IBC) (Oxiperm Pro OCD-162-30, -60)

TM04 8540 1312

7. Product selection

Preparation capacity [g/h] ClO ₂	Back-pressure P _{max} [psi (bar)]	Consumption of components			ClO ₂ dosing pump type	Weight [lbs (kg)]	Voltage / frequency	Oxiperm Pro type	Product number
		At max. capacity [gph (l/h)]		Dilution water [gph (l/h)]					
		HCl	NaClO ₂						
5	145 (10)	0.04 (0.15)	0.04 (0.14)	0.66 (2.5)	DDA AR	58-67 (26-30)	110/120V (50-60 Hz)	OCD-162-5-S/H3	95735155
10	145 (10)	0.08 (0.31)	0.08 (0.29)	1.32 (5)	DDA AR	62-71 (28-32)		OCD-162-10-S/H3	95735163
30	145 (10)	0.23 (0.88)	0.23 (0.87)	3.91 (14.8)	DDI AR	153-155 (69-70)		OCD-162-30-P/H3	95735178
55	145 (10)	0.45 (1.71)	0.43 (1.63)	8.59 (32.5)	DDI AR	186-188 (84-85)		OCD-162-60-P/H3	95736304

Notes:

Includes suction lances for 55-gallon tank.

Batch applications require additional ClO₂ pumps and controllers for every additional injection point.

How to size Oxiperm Pro®

This is a method for determining the correct size of Oxiperm Pro unit required for a specific application.

First, accurately determine the amount of chlorine dioxide required for the application. This is usually expressed in terms of either grams or pounds per hour (or day):

Demand = Organic / Microbio + Inorganic/Metals [PPM].

Regardless of model or output, all Grundfos Oxiperm Pro chlorine dioxide generators produce a product (basically ClO₂ and water) that has a concentration of 2 grams ClO₂ per liter.

The difference between the models is the amount of solution produced per hour. The example in this section describes the relative values for each model.

For instance, the OCD 162-5 model is designed to produce 5 grams/hr of chlorine dioxide. Since the ClO₂ concentration for all units is 2 grams/l, this means that the OCD 162-5 is producing 5/2 or 2.5 liters per hour of a 2 g/l concentration.

This table illustrates this relationship for the various Oxiperm Pro generators.

Model	Can continually produce:
OCD 162-5	5g/hr ClO ₂ or 2.5 l/hr of a 2 g/l solution
OCD 162-10	10 g/hr ClO ₂ or 5 l/hr of a 2 g/l solution
OCD 162-30	30 g/hr ClO ₂ or 15 l/hr of a 2 g/l solution
OCD 162-60	55 g/hr ClO ₂ or 27.5 l/hr of a 2 g/l solution

These values represent a maximum output for each of the units.

Since it would be unusual to encounter an application that requires the exact amount of ClO₂ generated by a unit, the output must be controlled by a 4-20 mA, analog signal to the ClO₂ dosing pump.

This signal is typically generated by either a flow meter and/or instrumentation sensing the level of ClO₂ in the water to be disinfected.

A slightly oversized unit is suggested to guarantee that the application requirement can be met. The 4-20 mA signal can then be ranged accordingly.

Example:

An application requires 45 grams per hour of ClO₂. The table in this section shows that the Oxiperm Pro model that can produce more than 45 g/hr is the OCD 162-60.

Adjust the ClO₂ dosing pump output for 20 mA to equal 45 g/hr. This would mean that the pump operating at maximum demand will provide 22.5 l/hr of a 2 g/l solution (22.5 x 2 = 45).

8. Accessories

Dosing pumps

ClO₂ dosing pumps

One pump needed for direct ClO₂ injection or transfer to a batch tank. Additional pumps required for each additional injection point.

- 100-240V, 50/60 Hz
- PVDF / PTFE / Ceramic materials of construction
- DDA inlet/discharge connections:
U7 (0.17 x 1/4", 1/4" x 3/8" and 3/8" x 1/2" tubing)
- 1/2" NPT adaptors available as accessories
- DDI inlet/discharge connections: 1/2" NPT



TM05 3928 1712



TM05 3932 1712

Generator size	Pump capacity	Pump model	Product number		
			Standard	Flow verification	Flow verification & measurement
162-5 and 162-10	0.00066 to 2 gph @ 232 psi	DDA 7.5-16	97722385	97722419	97722453
162-30 and 162-60	0.02 to 15.8 gph @ 145 psi	DDI 60-10	96717376	95712587	-

Note: Flow sensor requires 30 psi differential pressure.

ClO₂ pump control cables

Description	Length	Product number
4-20mA input, remote start/stop	16 ft	96609016
4-20mA output	16 ft	96632922
Alarm relay	16 ft	96609019

Multifunction valve

Back pressure/pressure relief/manual bleed-vent/anti-siphon. Includes fittings for 1/4 in., 3/8 in. and 1/2 in. tubing.

Description	Product number
MFV-G5/8-10 PV/T U7	95730820

Injection valve

Description	Product number
PVDF/PTFE, DN8 1/2" NPT outlet, U7 inlet (U7 = 1/4", 3/8" and 1/2" tubing connections)	95730934

Connectors

Description	Product number
1/2" NPT connectors (for hard piped installations)	97702505

Instrumentation

AQC Measuring cell	Parameter		Product number
	1	2	
Measuring cell AQC-D11, P-AU-X-X, QS-T-H US (Used with 162 Oxiperm Pro generator's controller)	ClO ₂		98438948



TM04 8599 3912

AQC measuring cell with controller	Parameter		Product number
	1	2	
Panel mounted pre-assembled system (for additional ClO ₂ pumps) DIA-2Q-A, D11-P-AU-PCB-QS-T, W-H US	ClO ₂	pH	98386801
	Alternate ORP probe	ORP	96609162
	ORP buffer solution		96609166
	Spare ClO ₂ electrode		91835242



TM04 8691 4512

Conex DIA-G gas warning unit

Description	Product number
Conex DIA-G-P,CDP-B,W-J: 110/240 V, 50-60 Hz <ul style="list-style-type: none"> with potentiostatic chlorine gas sensor measuring range 0.00 to 1.00 ppm 	95700854



TM04 1289 2109

Full technical details available for download at Grundfos WebCAPS, linked at www.grundfos.us.

Photometer

Compact photometer for quick determination of the concentration of chlorine dioxide and chlorite at the extraction point.

Description	Product number
DIT-L photometer with case <ul style="list-style-type: none"> Chlorine dioxide measuring range: 0.02 - 11.0 mg/l Chlorite measuring range: 0.01 - 6.0 mg/l Supplied with: 4 batteries, 1 manual, 1 Certificate of Compliance, 3 round vials with cap and gasket, 1 cleaning brush, 1 plastic stirring rod, 1 starter kit for 100 chlorine dioxide measurements 	95727743
Testing reagents for the determination of chlorine dioxide, for 250 measurements:	
<ul style="list-style-type: none"> DPD No. 1 tablets 	95727747
<ul style="list-style-type: none"> DPD No. 3 tablets 	95727750
<ul style="list-style-type: none"> Glycine tablets 	95727752
Additional testing reagents for the determination of chlorite, for 100 measurements (not included in DIT-L starter kit):	
<ul style="list-style-type: none"> DPD Acidifying tablets 	98032751
<ul style="list-style-type: none"> DPD Neutralizing tablets 	98032752



TM04 8452 4711

Suction lines

Generator size	Tank size [Gal (liter)]	Tubing connection	Material	Product number
162-5 and 162-10	208 (55)*	1/4 in. (4/6 mm)	NaClO ₂	98163678
			HCl	98163679
162-30 and 162-60	208 (55)*	6/12 mm	NaClO ₂	98164283
			HCl	98164286

*Included with standard generator

Connections

for	Description	Product number
PTFE hose 4/6** to dosing pump (1)	Connection to multifunction valve DN 8, G 5/8	96727601 (529-442)
PTFE hose 4/6** from batch tank to external dosing pump (DDI 209)	Connection to suction side G 3/8	91835694 (529-013)
PTFE-hose 4/6** for dosing pumps (3) (OCD-162-5/-10)	T-piece (3 x 4/6**), PVDF	95714891 (526-174)
PTFE-hose 9/12* for 2 dosing pumps (3) (OCD-162-30/-60)	T-piece (3 x 9/12), PTFE	95720337 (526-177)
PTFE-hose 9/12	PVC/FKM ball valve, DN 10, with PTFE connection 9/12	95721555 (526-178)

* Note: For connection of PTFE-hose 4/6, a connection 96727601 (529-442) has to be ordered in addition.

** 4/6 mm equivalent is 1/4"

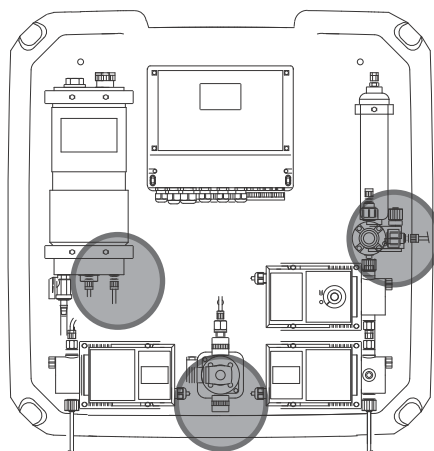

TM04 1297 2109

Fig. 14 Overview connections

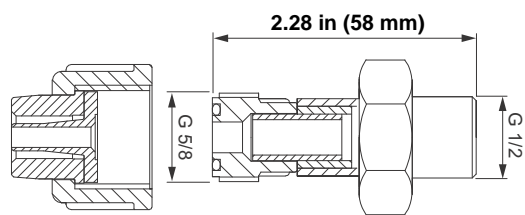

TM04 1292 2109

Fig. 15 Hose connection (fig. 16) with adaptor G 1/2, G 5/8 male thread

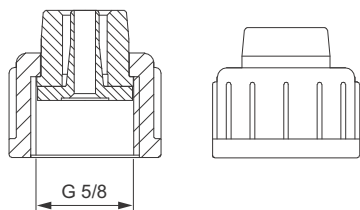

TM04 1288 2109

Fig. 16 Hose connections G 5/8 female thread

Annual maintenance kits

Oxiperm Pro systems with SMART Digital pumps (post June 2012)

System	Kit product number
162-5 DDA 7.5 ClO ₂ pump, DDE precursor pumps	98153636
162-10 DDA 7.5 ClO ₂ pump, DDE precursor pumps	98153962
162-30 DDI 60 ClO ₂ pump, DDE precursor pumps	98162644
162-60 DDI 60 ClO ₂ pump, DDE precursor pumps	98382087

Oxiperm Pro systems (pre-June 2012)

System	Kit product number
162-5 DDI 5.5 ClO ₂ pump, DMI precursor pumps	95702445
162-10 DDI 5.5 ClO ₂ pump, DMI precursor pumps	95707853
162-30 DDI 60 ClO ₂ pump, DMI precursor pumps	95717916
162-60 DDI 60 ClO ₂ pump, DMX precursor pumps	95717920

Note: Additional spare parts not part of the annual maintenance kit are listed in the OCD 162 Service Manual.

9. Further product documentation

WebCAPS

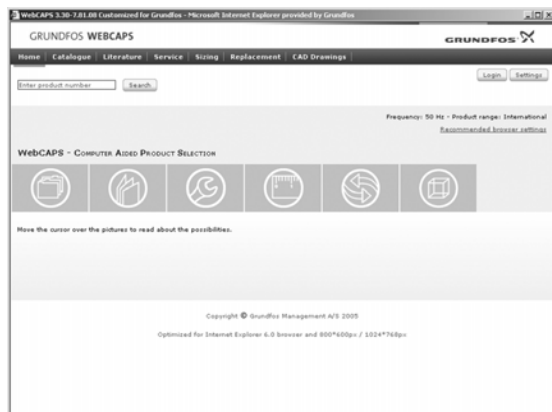

WebCAPS is a **Web-based Computer Aided Product Selection** program available on www.grundfos.com.

WebCAPS contains detailed information on more than 220,000 Grundfos products in more than 20 languages.

In WebCAPS, all information is divided into 6 sections:

- Catalog
- Literature
- Service
- Sizing
- Replacement
- CAD drawings.

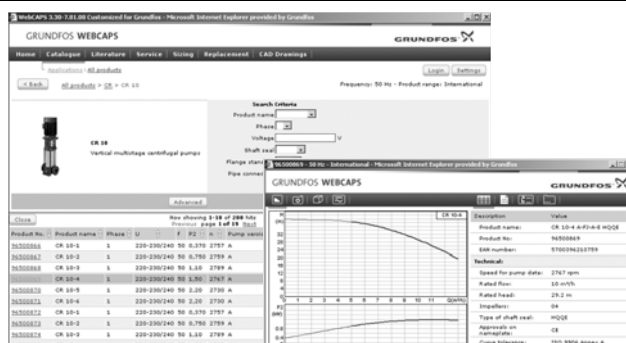

Catalog

This section is based on fields of application and pump types, and contains

- technical data
- curves (QH, Eta, P1, P2, etc) which can be adapted to the density and viscosity of the pumped liquid and show the number of pumps in operation
- product photos
- dimensional drawings
- wiring diagrams
- quotation texts, etc.

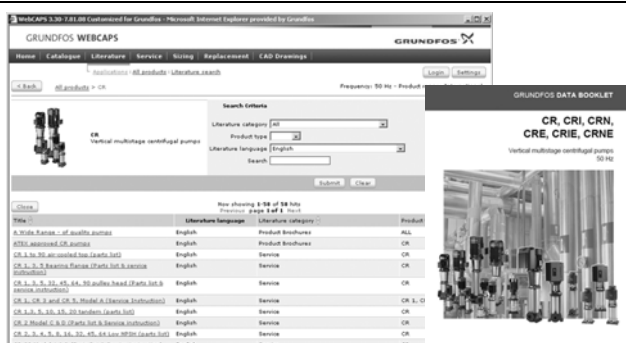

Literature

In this section you can access all the latest documents of a given pump, such as

- product guides/data booklets
- installation and operating instructions
- service documentation, such as Service kit catalog and Service kit instructions
- quick guides
- product brochures, etc.



Service

This section contains an easy-to-use interactive service catalog. Here you can find and identify service parts of both existing and discontinued Grundfos pumps.

Furthermore, this section contains service videos showing you how to replace service parts.



Sizing

This section is based on different fields of application and installation examples, and gives easy step-by-step instructions in how to

- select the most suitable and efficient pump for your installation
- carry out advanced calculations based on energy consumption, payback periods, load profiles, life cycle costs, etc.
- analyze your selected pump via the built-in life cycle cost tool
- determine the flow velocity in wastewater applications, etc.



Replacement

In this section you find a guide to selecting and comparing replacement data of an installed pump in order to replace the pump with a more efficient Grundfos pump. The section contains replacement data of a wide range of pumps produced by other manufacturers than Grundfos.

Based on an easy step-by-step guide, you can compare Grundfos pumps with the one you have installed on your site. When you have specified the installed pump, the guide will suggest a number of Grundfos pumps which can improve both comfort and efficiency.

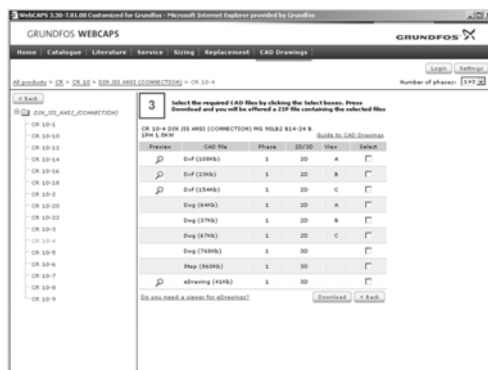

CAD drawings

In this section it is possible to download 2-dimensional (2D) and 3-dimensional (3D) CAD drawings of most Grundfos pumps.

These formats are available in WebCAPS:

- 2-dimensional drawings:**
- .dxf, wireframe drawings
 - .dwg, wireframe drawings.
- 3-dimensional drawings:**
- .dwg, wireframe drawings (without surfaces)
 - .stp, solid drawings (with surfaces)
 - .eprt, E-drawings.



WinCAPS



WinCAPS is a **Windows-based Computer Aided Product Selection** program containing detailed information on more than 220,000 Grundfos products in more than 20 languages.

The program contains the same features and functions as WebCAPS, but is an ideal solution if no Internet connection is available.

WinCAPS is available on CD-ROM and updated once a year.

L-OXI-PG-02

98442330 0413

ECM: -

GRUNDFOS Pumps Corporation

17100 West 118th Terrace
Olathe, Kansas 66061
Phone: +1-913-227-3400
Telefax: +1-913-227-3500

GRUNDFOS Canada Inc.

2941 Brighton Road
Oakville, Ontario L6H 6C9
Canada
Phone: +1-905 829 9533
Telefax: +1-905 829 9512

Bombas GRUNDFOS de Mexico S.A. de C.V.

Boulevard TLC No. 15
Parque Industrial Stiva Aeropuerto
Apodaca, N.L. Mexico 66600
Phone: +52-81-8144 4000
Telefax: +52-81-8144 4010

GRUNDFOS 